

# Earphones in eardefenders EAR-10 / EAR-11

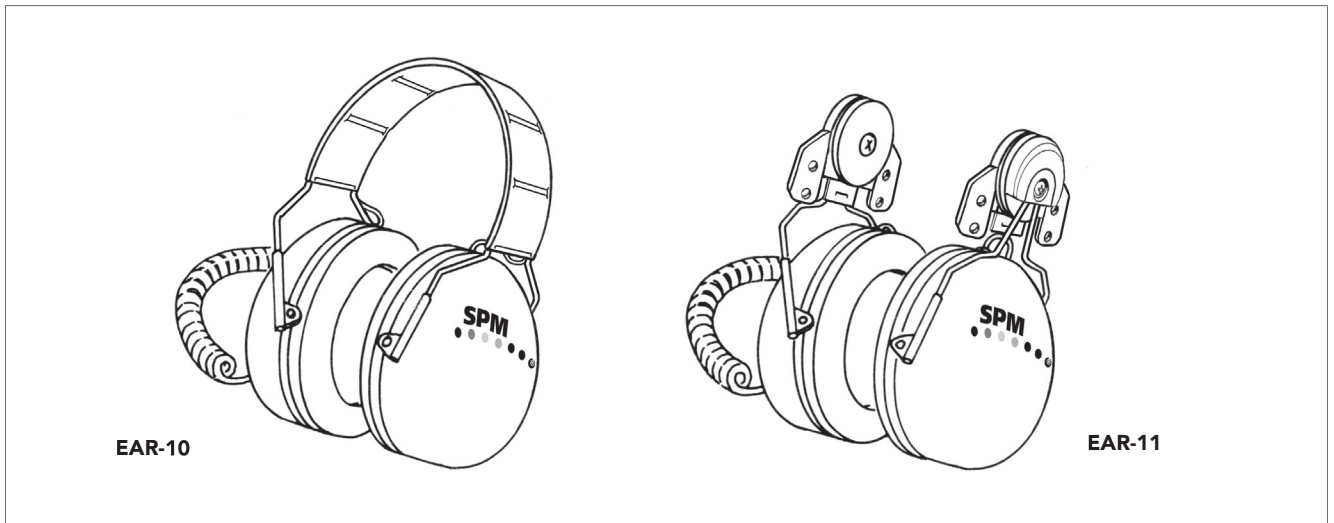

EAR-10 and EAR-11 are specially selected earphones, providing excellent sound reproduction even in noisy environments.

- Individually sprung headband wires of stainless sprung steel provide an even distribution of pressure around the ears. Steel headband wires retain their resilience better than plastic through a wide temperature range.
- Low, two-point fasteners and easy height adjustment with no protruding parts.
- Soft, wide foam and fluid-filled sealing rings with built-in pressure-evening channels provide low pressure, effective sealing and ideal comfort.
- Connection cord, 0.75 to 1.4 m, of soft spiral polyurethane with a modular telephone connector.

The earphones with eardefenders are tested and approved in accordance with PPE directive 89/1686/EEC and EMC directive 89/336/EEC to meet the demands for CE labelling.

## Headset, EAR-10

The headset EAR-10 is a mono telephone set with two parallel connected earphones. It has a collapsible headband for convenient storage when you are not using the earphones with eardefenders.

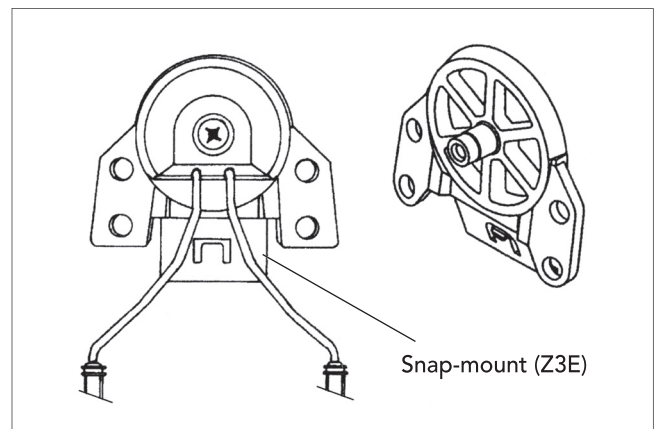

## Earphones for helmet, EAR-11

Earphones EAR-11 fit most safety helmets available in the market today. The earphones have standard snap-mounts (Z3E) and are adapted to a specific helmet by a simple manipulation.

To mount the headphone, snap the helmet attachment into the slot on the helmet. Note: The cups can be set in three positions: working position, ventilation position and parking position. When in use, the cups must be placed in working position. Press the wires inward until you hear a click on both sides. Make sure that the cup and the headband wire in working position are not pressing on the helmet lining or the edge of your hardhat so that leakage can occur. Parking position should not be used if the cups are damp inside after an intense period of use.

