

CMM System - Vibration Monitoring Rack Module VMR-BO

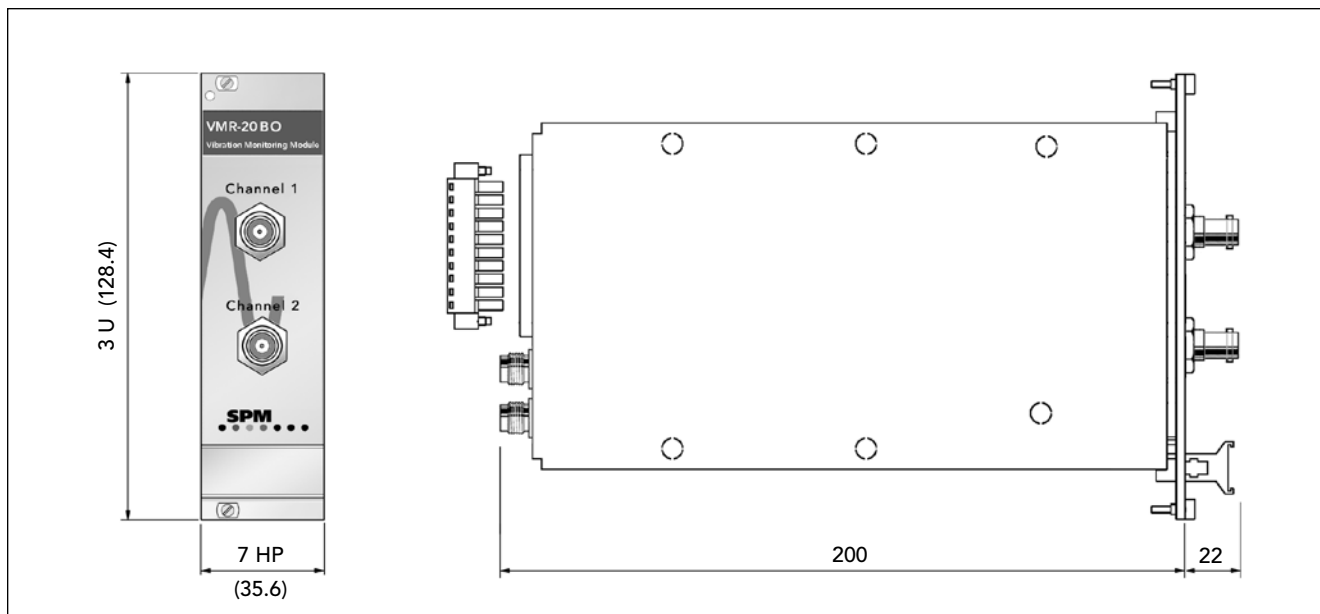

Vibration Monitoring Rack Modules VMR-BO are programmable converters which supply a 4-20 mA signal proportional to the RMS-value of vibration velocity. They have bypass outputs for connection of portable instruments.

There are four versions:

VMR-14 BO: 1 channel, frequency range 10–1000 Hz

VMR-15 BO: 1 channel, frequency range 3–1000 Hz

VMR-20 BO: 2 channels, frequency range 10–1000 Hz

VMR-21 BO: 2 channels, frequency range 3–1000 Hz.

The frequency range of 3 to 1000 Hz is suitable for machines with rotational speed down to 180 r.p.m.

The measuring range can be DIP switch set to either 0 to 5, 0 to 10, 0 to 20 or 0 to 40 mm/s.

The 4-20 mA output can be supplied to a display module type DMM/DMR, to a PLC or to a computer controlled monitoring system (e.g. SPM's CMS System).

A transducer line fault causes an output of <1 mA. If this should interfere with PLC operations, the min. output can be jumper set to 4 mA, individually for each channel.

The vibration transducer is connected via coaxial cable with TNC connector. The modules are mounted in standard 19" rack and supplied with 12 to 24 V DC.

The portable instrument SPM Leonova (or similar) can be connected to the bypass outputs on the front panel via a coaxial cable with BNC connectors.

Technical data

Measuring method:	vibration severity similar to ISO 10816 (modified frequency range, VMR-15/21 BO)
Channels:	1 (VMR-14/15 BO), 2 (VMR-20/21 BO)
Measuring range 1:	0 - 5 mm/s (0 - 0.19 inch/s)
Resolution:	3.2 mA = 1 mm/s; 1 mA = 0.313 mm/s
Measuring range 2:	0 - 10mm/s (0 - 0.39 inch/s)
Resolution:	1.6 mA = 1 mm/s; 1 mA = 0.625 mm/s
Measuring range 3:	0 - 20mm/s (0 - 0.78 inch/s)
Resolution:	0.8 mA = 1 mm/s; 1 mA = 1.25 mm/s
Measuring range 4:	0 - 40mm/s (0 - 1,57 inch/s)
Resolution:	0.4 mA = 1 mm/s; 1 mA = 2.5 mm/s
Frequency range:	10 to 1000 Hz (VMR-14/20) 3 to 1000 Hz (VMR-15/21)
Transducer type:	SLD121, TRV18, TRV19
Transducer cable:	coaxial cable, SPM 90005-L, or 90267-L, (L = max. 50 m)
Analog output:	4 to 20 mA, no galvanic separation
Fault indication:	≤ 1 mA out for open or short circuit
Loop resistance:	100 Ω. Higher resistance will reduce signal accuracy (max. 400 Ω at 12 V, 800 Ω at 24 V)
Power supply:	12 to 24V DC (± 10%, according to EN 50082-2)
Supply current:	max 0.1 A
Temperature range:	0° to 55° C
Vibration exposure:	max. 5 mm/s RMS
Design:	anodised aluminium, not protected
Input connectors:	TNC, silver plated brass, 10–15 μ
Output connectors:	screw terminals for cable max. 1.5 mm ² , connector plug included
Bypass outputs:	BNC connectors for connection of SPM Leonova or similar instrument
Mounting:	19" rack
Dimensions:	3 U x 7 HP x 222 mm, DIN 41494
Weight:	210 g (VMR-14 BO/15 BO) 350 g (VMR-20 BO/21 BO)

